

medifa 5000

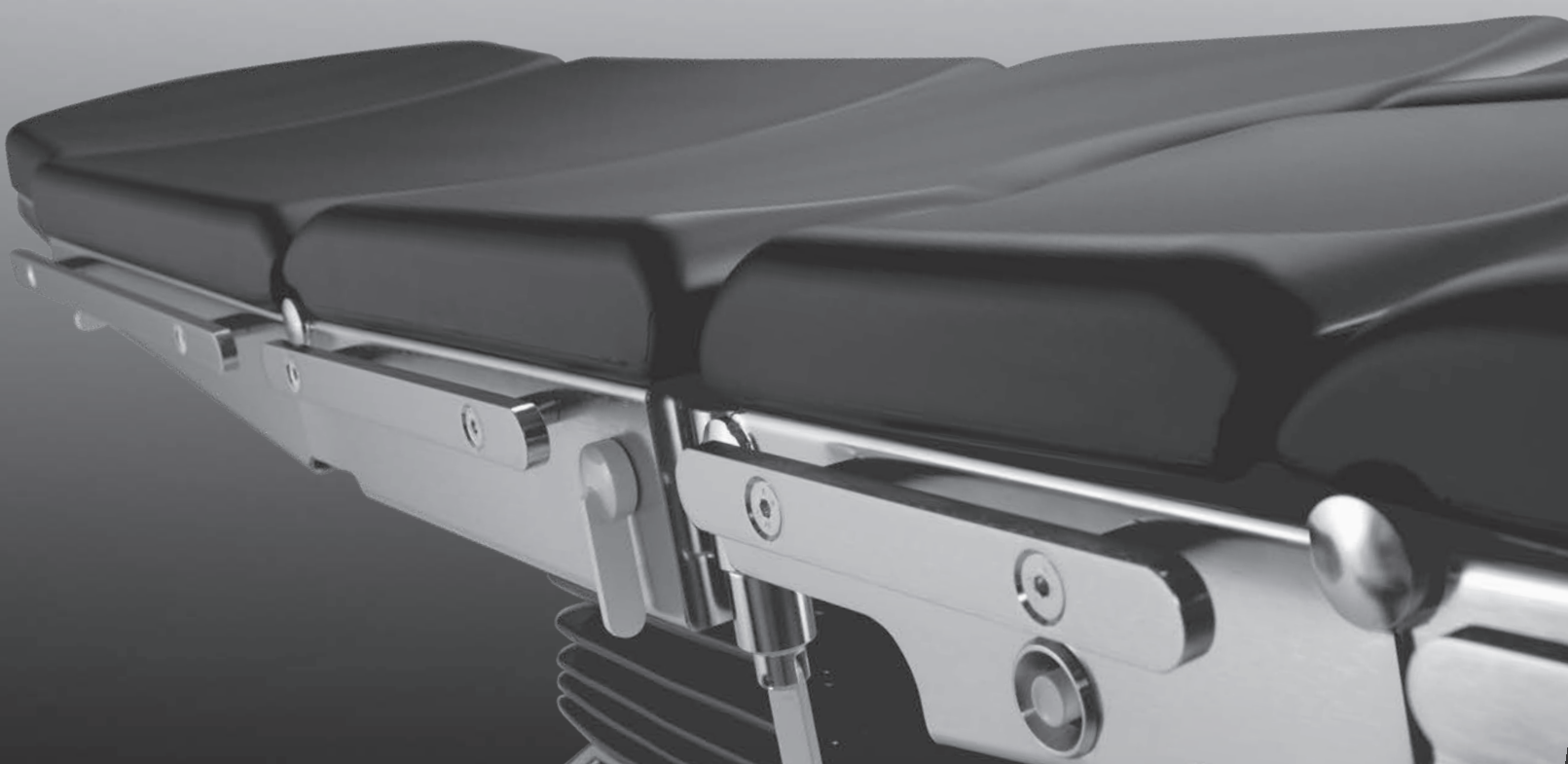

**Mobile day surgery
operating tables**

we care.

WWW.MEDIFA.COM | A COMPANY OF THE HOHNHAUS & JANSENBERGER GROUP



Perfection and Ergonomics

Diversity of variations with different adjustment possibilities

Polished high quality stainless steel edition (ChrNiSt, 1.4301)

Optimal to clean and disinfect

Unique price performance ratio

Easy handling and maintenance

Integrated batteries and charging unit

Hand switch with coloured display

Various capabilities and storing possibilities

Suitable for x-ray and c-arm applications

Wide range of accessories for all surgical disciplines

Maximum permissible overall load up to 250 kg

Three memory positions



Functionality and Design



Easy maneuverability by means of double swivel castors and excellent foot access by special base construction



Fifth castor for effortless movement (optional, art.-no. 50645, except models 505220-505325)



Coloured levers ensure quick and easy handling



Additional control panel at the column with battery indicator



Additional possibility to activate adjustments by foot switch (optional, art.-no. 604060, cannot be retrofitted)



Saving and activating of three different memory positions by means of hand switch



Feature selection of each manual adjustment by using corresponding lever



Basic hydraulic functions are operated by foot pedals



Electrical adjustments by means of hand switch, with integrated coloured display and battery indicator



Possibility for adjustment of kidney bridge by hand crank (optional, art.-no. 61655)



Ergonomic formed PUR upholsteries, electrically conductive, H = 60 mm (basic configuration)

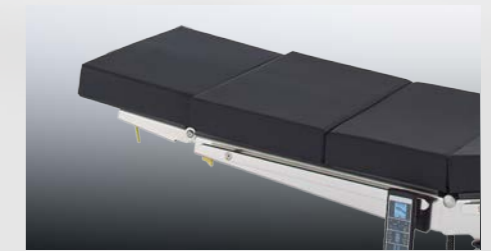

Alternative padding of lying surface with three-layered, visco elastic comfort upholsteries, H = 80 mm, detachable, electrically conductive (optional, art.-no. 5000SF)

Models - Manual Versions



501130

- Continuous X-ray cassette tunnel from head to foot end
- Lateral guide rails for attachment of accessories, stainless steel, 25 x 10 mm
- PUR-upholsteries, electrically conductive, detachable
- Mobility by four double leading castors \varnothing 125 mm, with central brake
- Height adjustment by foot operated hydraulic pump from 750 mm up to 1000 mm
- Gas spring supported Trendelenburg adjustment from -30° up to $+30^\circ$
- Lateral tilt by hand crank up to 20° , hand crank insertable at both sides
- Gas spring supported adjustment of back rest from -40° up to $+70^\circ$
- Adjustment to flex / reflex position
- Weight of the table: 150 kg
- Floor space required: (l x w) 920 mm x 520 mm



501135

Same as 501130, however with manual sliding table top up to 310 mm



Illustrations with accessories



503220

- Continuous X-ray cassette tunnel from head to foot end
- Lateral guide rails for attachment of accessories, stainless steel, 25 x 10 mm
- PUR-upholsteries, electrically conductive, detachable
- Mobility by four double leading castors \varnothing 125 mm, with central brake
- Height adjustment by foot operated hydraulic pump from 750 mm up to 1000 mm
- Trendelenburg adjustment by foot operated hydraulic pump from -30° up to $+30^\circ$
- Lateral tilt by foot operated hydraulic pump up to 20°
- Adjustment of back rest by foot operated hydraulic pump from -40° up to $+70^\circ$
- Adjustment to flex / reflex position-
- All adjustments foot pump operated (hand free adjustments!)
- Weight of the table: 160 kg
- Floor space required: (l x w) 920 mm x 520 mm



503225

Same as 503220, however with manual sliding table top up to 310 mm



Illustrations with accessories

Models - Electric Versions



504220

- Power supply 110 V or 220 V, 50-60 Hz, additionally integrated batteries incl. battery charger
- Corded hand switch with integrated colour display and battery indicator for electrical functions
- Additional operating panel at the column
- Continuous X-ray cassette tunnel from head to foot end
- Lateral guide rails for attachment of accessories, stainless steel, 25 x 10 mm
- PUR-upholsteries, electrically conductive, detachable
- Mobility by four double leading castors \varnothing 125 mm, with central brake
- Powered height adjustment from 780 up to 1080 mm
- Powered Trendelenburg positioning from -30° up to $+25^\circ$
- Powered lateral tilt up to 20°
- Gas spring supported adjustment of back rest from -40° up to $+70^\circ$
- Adjustment to flex/ reflex position
- Return to 0-position
- Weight of the table: 170 kg
- Floor space required: (l x w) 920 mm x 520 mm

504225

Same as 504220, however with powered sliding of table top up to 285 mm

504320

- Power supply 110 V or 220 V, 50-60 Hz, additionally integrated batteries incl. battery charger
- Corded hand switch with integrated colour display and battery indicator for electrical functions
- Additional operating panel at the column
- Continuous X-ray cassette tunnel from head to foot end
- Lateral guide rails for attachment of accessories, stainless steel, 25 x 10 mm
- PUR-upholsteries, electrically conductive, detachable
- Mobility by four double leading castors \varnothing 125 mm, with central brake
- Powered height adjustment from 780 up to 1080 mm
- Powered Trendelenburg positioning from -30° up to $+25^\circ$
- Powered lateral tilt up to 20°
- Powered back rest adjustment from -40° up to $+70^\circ$
- Adjustment to flex/ reflex position
- Return to 0-position
- Weight of the table: 175 kg
- Floor space required: (l x w) 920 mm x 520 mm

504325

Same as 504320, however with powered sliding of table top up to 285 mm



Models - Low Height Versions



505220

- Power supply 110 V or 220 V, 50-60 Hz, additionally integrated batteries incl. battery charger
- Corded hand switch with integrated colour display and battery indicator for electrical functions
- Additional operating panel at the column
- Continuous X-ray cassette tunnel from head to foot end
- Lateral guide rails for attachment of accessories, stainless steel, 25 x 10 mm
- PUR-upholsteries, electrically conductive, detachable
- Mobility by 2 centrally lockable and two directional double castors, Ø 125 mm
- Powered height adjustment from 600 up to 950 mm
- Powered Trendelenburg positioning from -30° up to +25°
- Powered lateral tilt up to 20°
- Gas spring supported adjustment of back rest from -40° up to +70°
- Adjustment to flex/ reflex position
- Return to 0-position
- Weight of the table: 170 kg
- Floor space required: (l x w) 910 mm x 510 mm

505225

Same as 505220, however with powered sliding of table top up to 275 mm



505320

- Power supply 110 V or 220 V, 50-60 Hz, additionally integrated batteries incl. battery charger
- Corded hand switch with integrated colour display and battery indicator for electrical functions
- Additional operating panel at the column
- Continuous X-ray cassette tunnel from head to foot end
- Lateral guide rails for attachment of accessories, stainless steel, 25 x 10 mm
- PUR-upholsteries, electrically conductive, detachable
- Mobility by 2 centrally lockable and two directional double castors, Ø 125 mm
- Powered height adjustment from 600 up to 950 mm
- Powered Trendelenburg positioning from -30° up to +25°
- Powered lateral tilt up to 20°
- Powered back rest adjustment from -40° up to +70°
- Adjustment to flex/ reflex position
- Return to 0-position
- Weight of the table: 175 kg
- Floor space required: (l x w) 910 mm x 510 mm

505325

Same as 505320, however with powered sliding of table top up to 275 mm



Overview medifa 5000

		Adjusting range	501130	501135	503220	503225
	Height adjustment	750 - 1000 mm	○	○	○	○
	Height adjustment	780 - 1080 mm				
	Height adjustment	600 - 950 mm				
	Trendelenburg	-30° / +30°	■	■	○	○
	Trendelenburg	-30° / +25°				
	Lateral tilt	-20° / +20°	■	■	○	○
	Back rest adjustment	-40° / +70°	■	■	○	○
	Sliding table top	310 mm		■		■
	Sliding table top	285 mm				
	Leveling					
	Flexion		■	■	○	○
	Central brake		■	■	■	■
	Kidney bridge		◆	◆	◆	◆
	Fifth castor		◆	◆	◆	◆
	Memory (3 Positions)					
	Maximum permissible overall load		200 kg	200 kg	250 kg	250 kg

504220	504225	504320	504325	505220	505225	505320	505325
●	●	●	●				
				●	●	●	●
●	●	●	●	●	●	●	●
●	●	●	●	●	●	●	●
■	■	●	●	■	■	●	●
	●		●		●		●
●	●	●	●	●	●	●	●
■●	■●	●	●	■●	■●	●	●
■	■	■	■	■	■	■	■
◆	◆	◆	◆	◆	◆	◆	◆
●	●	●	●	●	●	●	●
200 kg	200 kg	250 kg	250 kg	200 kg	200 kg	250 kg	250 kg

Technical information

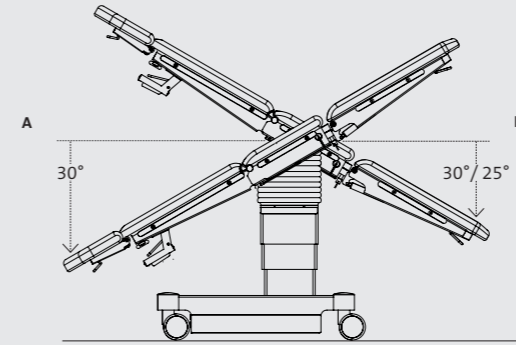
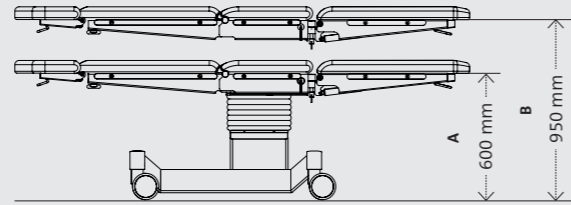
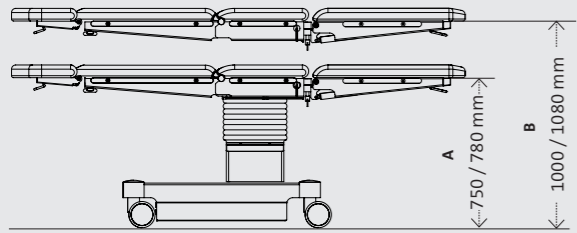

Models	Adjusting range	
	Höhe A	Höhe B
501130 / 501135 / 503220 / 503225	750 mm	1000 mm
504220 / 504225 / 504320 / 504325	780 mm	1080 mm

Models	Adjusting range	
	Höhe A	Höhe B
505220 / 505225 / 505320 / 505325	600 mm	950 mm

Models	Adjusting range	
	A	B
501130 / 501135 / 503220 / 503225	30°	30°
504220 / 504225 / 504320 / 504325	30°	25°
505220 / 505225 / 505320 / 505325	30°	25°

Models	Intraoperative imaging
501135 / 503225	
504225 / 504325 505225 / 505325	

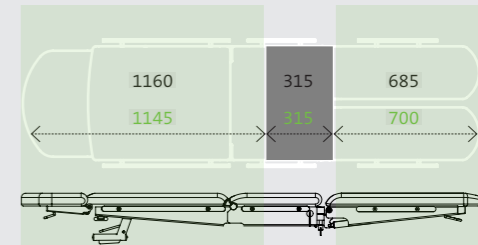
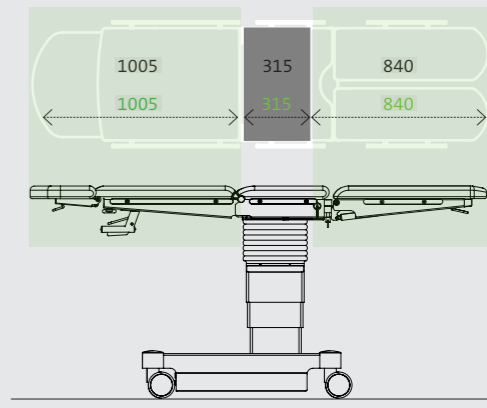
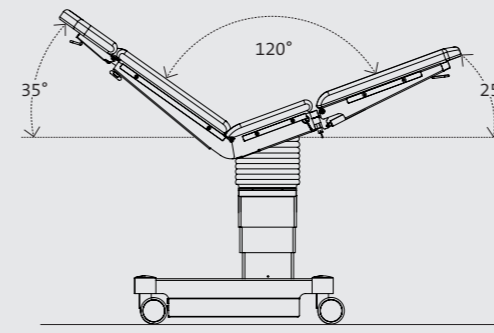
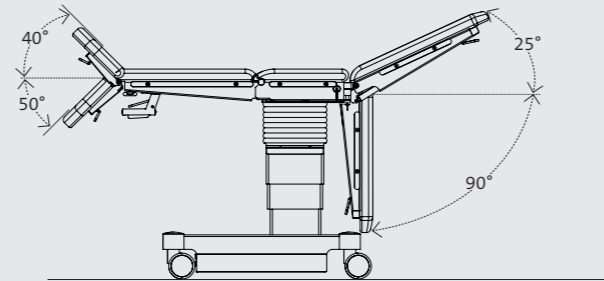
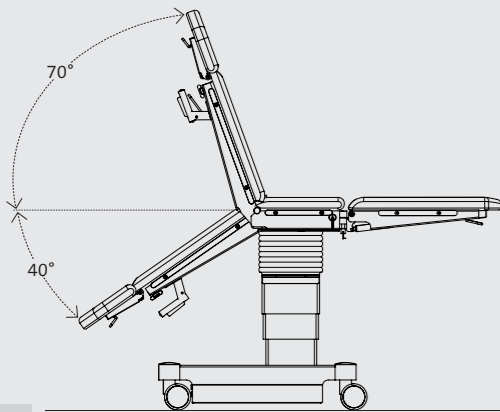
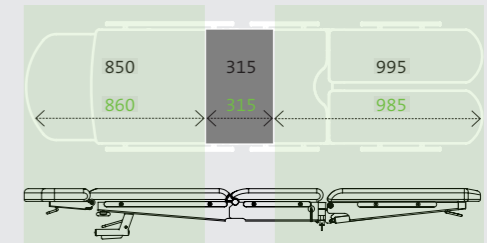
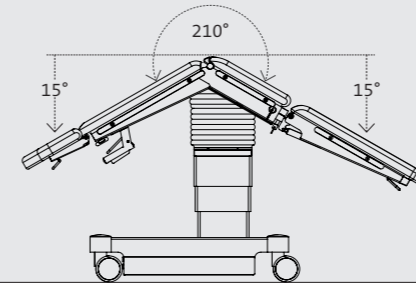
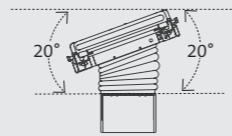
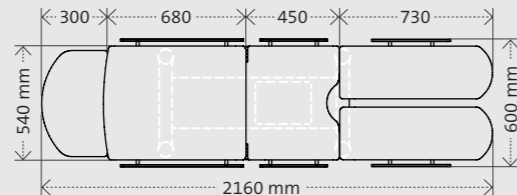
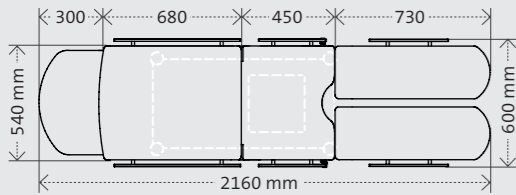

Sliding of table top left-sided

Sliding of table top right-sided

Basic position

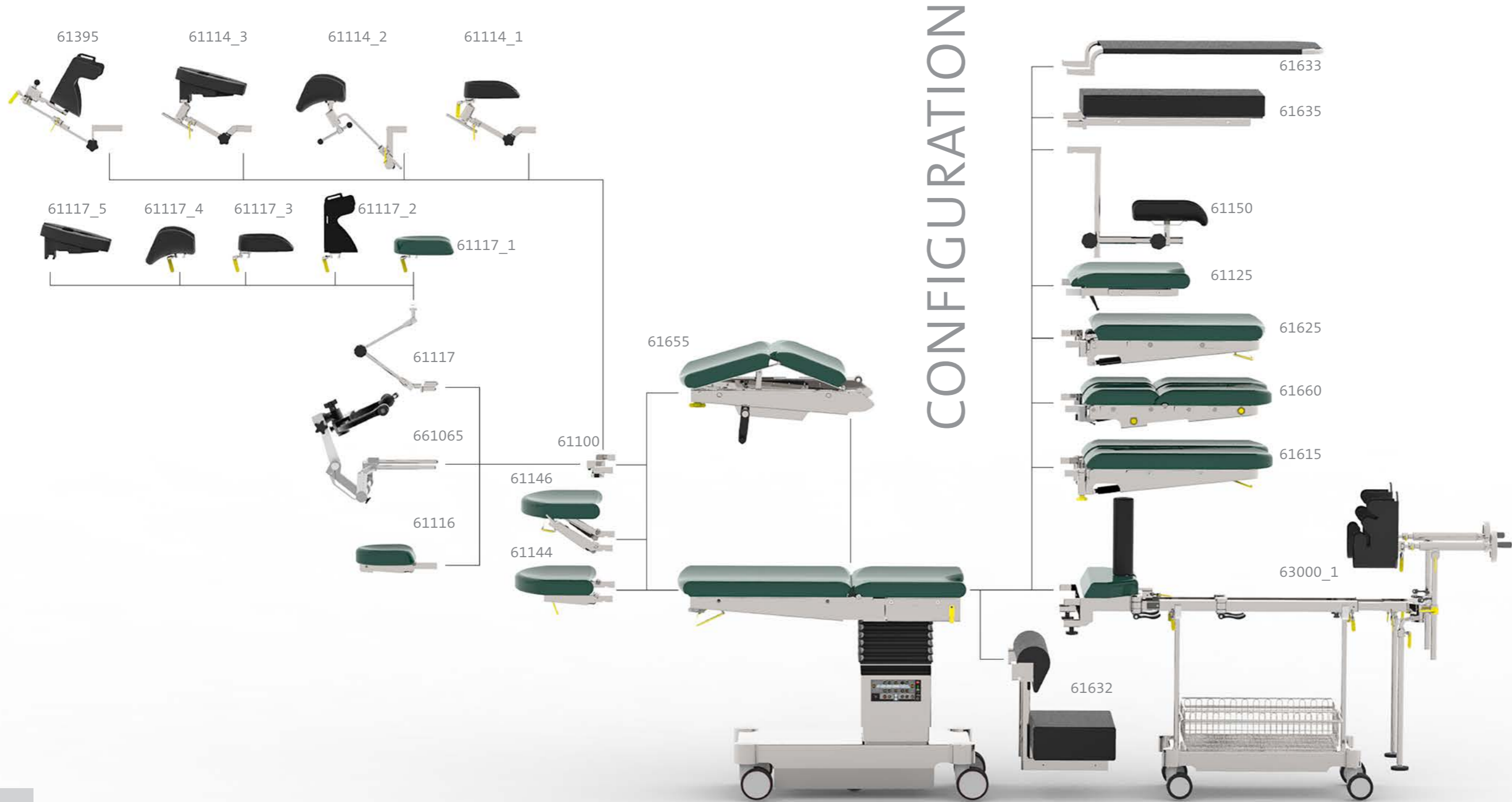

Additional accessories

A wide range of optional accessories complements the application spectrum of our operating tables.

For central storage of accessories we offer an accessory trolley (art.-no. 341045) completely made of stainless steel. The trolley has five insertions for storing of upholstery segments and five guide rails for attachment of additional accessories as well as a shelf for smaller accessories.



Our full range of products:

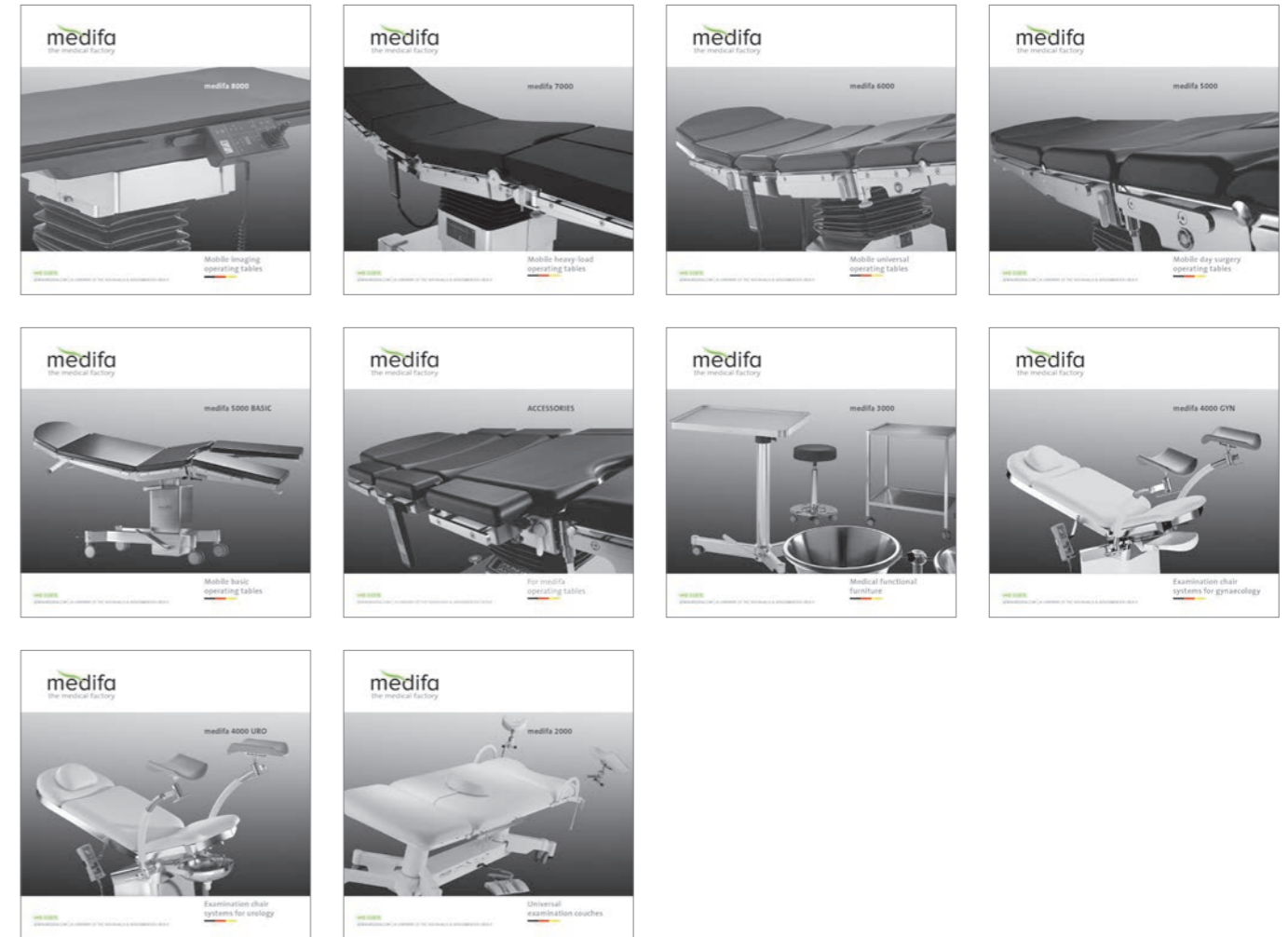

**medifa**
the medical factory



medifa GmbH & Co. KG
Industriestrasse 5
57413 Finnentrop

fon +49 2721 71 77 -0
fax +49 2721 71 77 -15

www.medifa.com
info@medifa.com



Version 0002-17-EN
Data subject to change without notice.

Made in Germany

